



Connections

VOLUME 17, ISSUE 12

THURSDAY, JUNE 24, 2010

THE WHAT AND WHY

I need a car. I was involved in what should hardly have been more than a fender bender but totaled my car on Memorial Day. I'll confess that Sue and I don't know so much about buying cars so we are starting to ask for advice. Where are the good deals, and who are the reliable people to buy a car from?

Now if that's all I ask people I'm going to get lots of suggestions, half of which may be useful. It helps to know a few things. It would help to know *what* kind of car we're looking for and *how* we plan to use it.

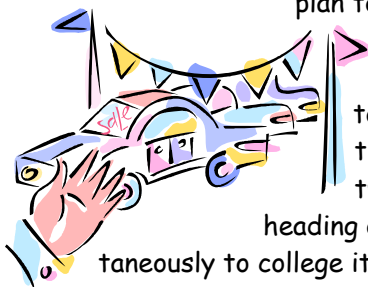

It helps to know that with two kids

heading off simul-

taneously to college it's got to be a used car. It helps to know that we Burchills value reliability above color or comfort or drive. It would really help to know that right now we're hoping not to go too far above what the insurance company is giving us for our dearly departed Hyundai.

Knowing all this would really make a difference in what kind of advice our friends might offer. Sometimes just knowing *the what and why* puts our conversations with

JOYFUL NOISE SUNDAY

Join Us for Potluck Dinner

Don't forget to come Sunday evening for a great potluck dinner and then a wonderful concert by the Joyful Noise youth mission team from Manassas, VA. Bring your well-filled basket to share at 5:15 p.m. and stay for the concert following. Meat, table service and drink will be provided. Looking forward to seeing you there and sharing a time of fellowship.



one another in a more helpful context.

* * *

The same is true for us as men and women of faith. It's most decidedly true for those of who call St. Andrew our church home.

For instance, a comment was overheard recently about how cool the church was on a particularly hot Sunday morning. It was something along the lines of "Have we got money to burn around here?"

What folks don't understand is that our thermostats are carefully programmed and timed both in winter and summer around the ministries that take place here. The problem comes when people override that programming to suit their own momentary comfort. The people who feel free to adjust the thermostats often don't bother to readjust them when they leave. Hence we have

fits of heating/cooling pandemonium that drives our trustees and staff nuts.

There is a plan behind how our thermostats are set. If for some reason it is uncomfortable for you, please find someone familiar with our system that can help you. We'd strongly prefer not to have members and/or visitors randomly adjusting the temperature. If there is no trustee or staff around, then please use the triangular buttons on the right outside of the thermostat to "bump" up or down the temperature (no more than a couple of degrees either way). And when you leave a room that you've personally adjusted, please change it back to where it was when you got there.



We really don't have money to

(Continued on page 2)

(Continued from page 1)

burn and we'd much rather use savings in our utility bills to fund ministry. If you think it through with us, I believe you'll see that being a little uptight about our thermostats makes real, practical sense in the long run.

We need more handicapped or reserved parking places. *The what and the why* in this case is that we have got single parents managing multiple small kids; we have got faithful members with chronic physical difficulties, and we've got any number of folks recovering from surgery, chemo, etc.

On Sunday morning why don't we all agree not to park in the spots outside the front doors of the church unless we need to. We'll let you determine what "need to" means, but rest assured it probably doesn't include rain, running late, or being really tired from the night before.

Some of us remember when St. Andrew was located on Meridian St. Our total parking equaled the number of parking places that are currently outside the front of our church. We wanted to make sure that folks who needed those spots got them. We also wanted to make sure that there was always a spot or two available for first time visitors. I remember church consultant Doug Anderson saying to us: "leaders lead." What he meant was leaders park as far away as they can so that others that might come could and would come.

I'm thinking it's time to honor a

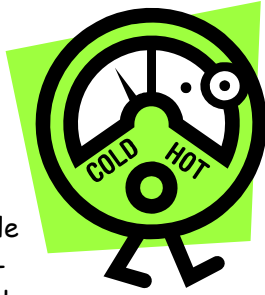

Member of the Month at St. Andrew. We should announce on the first Sunday of each month who the winner is and then give them a 24/7 parking permit for a specially marked, reserved parking spot. I suggest we reserve the spot furthest from the church for the honoree. It would send a wonderful message: the best of St. Andrew are those who are most cheerfully inconvenienced in pursuit of the mission and purpose of the church.

This wouldn't be nearly as important during business hours or on meeting nights when those spots are in ample supply. On the other hand what a great message we would send the Boy Scout Troop or the tutoring folks or those attending weddings/funerals if we were seen intentionally giving up open spaces nearby for a long walk through a windy or hot parking lot. If they asked we could tell them what Jesus said about the last being first or the greatest in the kingdom being those who put the needs of others first.

Being together in community means we look beyond the obvious assumptions and do what we can to look and listen to *the what and why* behind so much of our life together. It's just what you do when you're trying to fulfill on a mission with several hundred of your closest friends.



SUMMER ADVENTURE WITH OUR CHILDREN

Do you enjoy art, cooking, games or movies? Would you like to teach a Sunday school lesson based on one



of the hobbies? We're looking for teachers for session three of our summer Sunday school which meets July 25, August 1, 8. You prep one lesson (curriculum provided) and teach it each of the three weeks to a different group of kids. It couldn't be easier or more fun!

We are also still looking for someone to teach the Sprouts (2 and 3 year olds) class during session 3 (July 25, Aug. 1, 8) and session 4 (Aug. 15, 22, 29). Please contact Melissa at 497-7755 or melissa@andrew-umc.org if you are interested!

THANK YOU, ST. ANDREW

Dear St. Andrew,
Thank you very much for the college send-off box. It was very kind of you to make it and send it to me and I am sure that I will be able to use its contents in the upcoming school year. It will also provide a good reminder that no matter where I go or what I do, God is always with me.



With gratitude,
Bryan Foster

ECHOES OF THE GOSPEL

Book Group Meeting

Sunday, July 18, 6-7:30 p.m.

The Complete Short Stories of Mark Twain

You and your friends are invited to St. Andrew's next book group meeting, **Sunday, July 18, 6-7:30 p.m.**, in Adult I. We will be talking about *The Complete Short Stories of Mark Twain*, which is the Greater Lafayette Community "One Great Read" for this summer. This year is the 100th anniversary of Mark Twain's death.

He is legendary as a humorist and outstanding story teller.

This special collection of sixty stories (a Bantam Classic paperback edition) is available for checkout at all of the local libraries.



This is a great chance to join our book group discussion without reading a whole book. We decided that each of us will pick one of the stories to read and lead the discussion for it. Those selected so far are "The Mysterious Stranger" (by Pastor Tim) and "Was it Heaven or Hell" (by Barb Jones). You can read just those...and as many of the other sixty as you wish. Some are just a few pages long.

"Echoes of the Gospel" is a group that talks about books, applying the lens of our faith and our understanding of lessons we learn from the Bible. It is an informal group and a good place to get to know others at St. Andrew. Some read every book and come to every session. Others attend just when the chosen book is of interest. You are always welcome to enjoy the conversation, whether you have read the book or not.

SUMMER SUNDAY SCHOOL

Session two of summer Sunday schools starts this Sunday. The children will rotate to a different station each week. All children will gather in the Children's Area before heading to their stations. The Sprouts class will continue to meet in their classroom as usual. Note: all grades are the child's grade during the 2009-2010 school year (grade just completed). Here is the schedule for the second session:

June 27

Sprouts—Sprouts Room



Preschool/kindergarten—Cooking
First/second grade—Storytelling
Third/fourth grade—Games

July 4

Combined Sunday School—Movie

July 11

Sprouts—Sprouts Room
Preschool/kindergarten—Games
First/second grade—Cooking
Third/fourth grade—Storytelling

June 18

Sprouts—Sprouts Room
Preschool/kindergarten—Storytelling
First/second grade—Games
Third/fourth grade—Cooking

GALACTIC BLAST WRAP UP

Vacation Bible School was a huge success. We had a great week with a record 178 children registered. Everyone had a great time with



Commander Liz and our favorite green gorilla, Galileo, during the Opening and Closing Assemblies each day. A lot of fun (and some learning, too) was had in a variety of cool stations (Rocket Rec, Astro Bistro, Moons & Tunes, Cosmic Crafts, Good News Galaxy, Orbital Observatory, and VBS Missions).

For this year's missions projects, the kids planted trees on the church property, brought in canned goods for the Church Women United Food Pantry, and collected money for Living Water International. A big "thank you" goes out to the 100+ volunteers who helped in a variety of ways. We couldn't offer this program if it weren't for the dedication of the people of St. Andrew!



"I HAVE SONGS YET TO SING..."

Hard as it is to believe, it takes more than just saying, "Hey! I want to be a preacher (I mean, how hard could it be?)" to be a United Methodist Pastor. This line of thinking is usually followed by something along the lines of: "What a swell gig! They only work one day a week!" ☺

Yes, Virginia, certification on any level in the United Methodist Church requires years of study and hard work. The first stage is called License to Preach School. This is an intensive, on-site, two-week course that gives the as yet untested pastor some basic info on how to be a pastor, and it also gives the conference a sense of whether you have what it takes to be a United Methodist Pastor, what gifts you have, what you need, whether your theological bent matches well with the United Methodist Church, etc.

This is a long-winded way of saying the 32 people in my licensing class were a very diverse mix of gender, ages, cultural backgrounds and theological perspectives. I say all this to tell you about one special man in this group. Let's call him Tommy.

He was a second-career pastor in his late 40's. He was also a full-blooded Native American from the Huron tribe in Northern Michigan. He was very proud of his heritage but very shy about talking about himself in groups. But, get him alone after class and he would talk about his heritage and his upbringing. I think we talked every avail-

able moment for the entire two weeks. I was fascinated.

It turns out his father was a "holy man." I'm not talking about a pastor in the modern, career-identifying way. As he said, his father was a man who lived a holy life, focused on God, following the ancient ways of his people. He said, "He loves and lives for God." His people came to his father for advice, interpreting of dreams and visions and, simply when they had nowhere else to turn. His father was a well-respected man in his tribe and indeed around the country among Native American people.

In my attempt to understand what a "holy man" was, I asked him if his father was a pastor? He said, "No. He was a holy man." And, then he told me a story about the first white preacher his people had ever seen, a traveling preacher who came, horseback, to their village to talk with the chief (one of his great-great-great (+) grandfathers) about becoming Christian. They let this traveling preacher live with them for a number of months, and the entire village came to hear him preach every Sunday morning. He said: "...it was the best entertainment they had at that time. They thought he was a comedian..."



Pennsylvania's Slate Run.

After several months, the pastor was preparing to move on and wanted the chief and his people to be baptized and start a church that would remain after he had gone. The chief, as politely as he was able, told him that they had enjoyed his stay and considered him a friend of their people, but, no, they would not be baptized nor start a "Jesus-Church." Flabbergasted, the preacher asked him why not? His grandfather (several times removed) said: "The God we follow is a 24 hour a day, 7 day a week God. We live with Him. We celebrate His moving among us and blessing us with what we need to survive. You worship for an hour on Sunday morning. We worship always."

In other words, at least in their opinion, the preacher practiced his faith for an hour on Sunday morning but didn't live his faith.

They neither wanted nor understood that kind of faith. I don't either.

So, when he said his father was a holy man, he meant that he was a man that lived his faith in a God that was real, could be seen and felt, communicated with and who regularly interacted with His

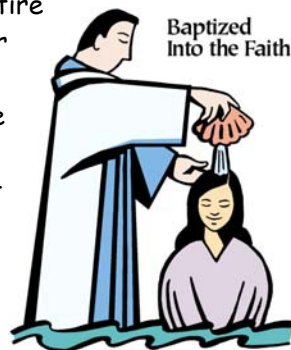

people. His father saw God in the seasons, in the bounty of the earth and the way loving people treated each other. I love that understanding of God: a real, living, moving God that still blesses and touches; much more than a



One of Pat's favorite rod/reel combos for trout - both considerably older than he.

mere symbol of "something good out there." I like it a lot.

Eventually, I asked him why he wanted to be a United Methodist Pastor. He said the usual things, that he felt called to serve God and his people, etc. But then he told me about the tradition of his people to "sing." I don't mean entertainment kind of singing, though they certainly did that. Briefly, he explained it as "...singing a story of what God wanted you to do." In sacred moments in his tribe's life, a holy man or woman would sing their prayers, their dreams, their needs and their longing to be more closely joined with God. It was a way of keeping in touch with their ancient culture but also a way to vision together as a community about what was to come.

He finished his answer about why he wanted to be a pastor with the simple phrase: "...because I have songs left to sing." I don't know for sure, but it seems to me that

he wasn't just talking about a job. He wanted to be a pastor because he had meaningful, purposeful living left to do. He wanted to live a faith that was more than an hour on Sunday morning. He wanted to live a faith that touched every part of his life and he wanted to help others to do that as well. He wanted to love his people as near to the way God loved them as he could - for as long as he could. He had "...songs to sing."

I'm finding that understanding beautiful and very meaningful to me as I wrap up my sabbatical journey. I'm looking forward to rejoining my church family in July and not only because I love you and I miss you - you never really worship at someone else's church like you do in your own family of faith. I'm looking forward to seeing you all soon because, to paraphrase Tommy: "I have songs yet to sing." WE have songs to sing together about the journey that lies ahead.

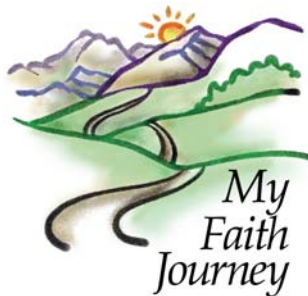

Recently, I saw a member of our congregation and they said, with a chuckle: "Well, you don't LOOK different!" Too true, and none are more disappointed about that than me - I was hoping to be mistaken for Brad Pitt when I returned! Unfortunately, when you see me next I'll look the same. I'll even sound the same, mores the pity; but I assure you I am not the same. You may

never even notice the difference, but there is a difference. In the resting, studying and wandering in Creation of the past couple of months God has renewed my call. I don't know how. I sure didn't see it coming - and, honestly, I don't even care. In ways I couldn't have imagined a couple of months ago, I am SO looking forward to the next part of the journey. And, my friends, that feels pretty good.

Pastor Pat

P.S. Now, let's be clear: when I say "I have songs yet to sing" please understand this in the spiritual context and don't expect my voice to have actually improved - sadly, not only do I look the same, but my singing is the same as well! I'm back in the office on 6 July!

THANK YOU FROM THE REIFS

*Dear St. Andrew Friends,
Thank you so much for the beautiful blanket we received upon the birth of our son, Dawson Patrick. We greatly appreciate your thoughtfulness, prayers, and warm wishes during this exciting time for our family.*

A special thank you to [the InTouch ministry] for delivering the blanket to us in Delphi. The Swaddling Cloth Ministry is a wonderful way to welcome a "new addition" into God's family!

*Sincerely,
The Reif Family
Dave, Stacy, Autumn, Dawson,
Matthew & Emily*

CHURCH YOUTH CONFERENCE AT PURDUE

On July 9-12, the New Apostolic Church will hold its National Youth Conference on the Purdue University campus. As part of the events that will take place, 1700 young people will participate in outreach programs on Saturday. These outreach programs will include a variety of projects for the LUM organization such as cleanup/painting projects at the camps and LUM building, preparing meals, stocking the food pantry just to name a few.

On Sunday, July 11, the NAC Youth Group will be performing a benefit concert for the Lafayette Urban Ministry specifically to raise funds to send under privileged children to summer camp. I have been working closely with the conference organizers to make the events for the weekend successful both from the standpoint of the community and in developing the youth to further understand what a blessing it is to serve God by serving others.

Sincerely,
Joe Micon

BENEFIT CONCERT FOR LUM

Supporting the mission to send under privileged children to LUM camp

Performers: New Apostolic Church National Youth Choir performing a concert entitled "Heritage with Soul"

Date: July 11

Time: 7:00 p.m.

Location:

Elliott Hall of Music
Purdue University
712 Third Street
West Lafayette, IN 46907

Tickets:

\$10.00 per person or \$5.00 for seniors and children 12 and under
-All proceeds will benefit LUM camp

Purchase Tickets:

Elliott Hall Box Office or Loeb Box Office (Stewart Hall) -
Hours: 10:00 a.m. to 4:00 p.m.,
Monday thru Friday
-to order by phone call 765-494-3933 or 1-800-914-7469

CENTER STAGE JUNE MEETING

Dick and Betty Nelson will be welcoming Center Stagers to their home this Sunday,



June 27, at 12:30 p.m., for our monthly carry-in lunch and social. Their address is 102 Hideaway Lane, West Lafayette. They need to know how many to plan for, so an accurate advance count could help them greatly; please let them know by email (rcnelson@purdue.edu, bmnelson@purdue.edu) or phone 765 - 463-3144) if you will be there.

Directions: About a mile north on Soldiers Home Road from US 52 (Sagamore Parkway), you will find Indian Rock Drive on the east (right) side of the road, with the Emmanuel Bible Church on the southeast corner of the intersection. Drive east on Indian Rock Drive. That road goes a couple of short blocks, then turns left (or north) and ends in a circle. Just before the circle opens out, you will see Hideaway Lane—the one lane road that goes right (east) into the woods. As you approach the woods, you will see a Hideaway Lane sign. Enter the woods and they are the first house on your left.

Parking: We suggest you park in or near the circle, since parking in the woods is limited — please save driveway space for those who have 4 or more passengers, or who have a degree of disability.



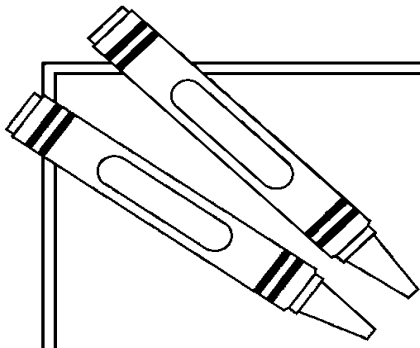

Just for **KIDS**

A Biblical Picnic

In the warm weather months we like to go on picnics. What do you pack in your picnic basket? If you lived in Bible times, what do you think you might have packed?

Below are the names of some people in the Bible. Use the code to find out what each person may have taken on a picnic. Look up the verses to read more about each person.

Code:	A	B	C	D	E	F	G	H	I	J	K	L	M	N	O	P	Q	R
	1	2	3	4	5	6	7	8	9	10	11	12	13	14	15	16	17	18
	S	T	U	V	W	X	Y	Z										
	19	20	21	22	23	24	25	26										

1. Saul $\overline{16} \overline{15} \overline{13} \overline{5} \overline{7} \overline{18} \overline{1} \overline{14} \overline{1} \overline{20} \overline{5} \overline{19}$ (*1 Samuel 14:2*)
2. Jonathan $\overline{8} \overline{15} \overline{14} \overline{5} \overline{25}$ (*1 Samuel 14:29*)
3. Eve $\overline{6} \overline{18} \overline{21} \overline{9} \overline{20}$ (*Genesis 3:6*)
4. Daniel and friends $\overline{22} \overline{5} \overline{7} \overline{5} \overline{20} \overline{1} \overline{2} \overline{12} \overline{5} \overline{19}$ (*Daniel 1:12-16*)
5. John the Baptist $\overline{12} \overline{15} \overline{3} \overline{21} \overline{19} \overline{20} \overline{19}$ (*Matthew 3:4*)
6. The 5,000 people $\overline{12} \overline{15} \overline{1} \overline{22} \overline{5} \overline{19} \& \overline{6} \overline{9} \overline{19} \overline{8}$ (*Matthew 14:17*)
7. Israelites in Egypt $\overline{3} \overline{21} \overline{3} \overline{21} \overline{13} \overline{2} \overline{5} \overline{18} \overline{19}$ (*Numbers 11:5*)
8. Esau $\overline{19} \overline{20} \overline{5} \overline{23}$ (*Genesis 25:34*)
9. Isaac $\overline{23} \overline{9} \overline{12} \overline{4} \overline{7} \overline{1} \overline{13} \overline{5}$ (*Genesis 25:28*)
10. Ruth $\overline{7} \overline{18} \overline{1} \overline{9} \overline{14}$ (*Ruth 2:1-4*)

St. Andrew Connections

St. Andrew United Methodist Church
4703 N. 50 W.
West Lafayette, IN 47906
Thursday, June 24, 2010

RETURN SERVICE REQUESTED

NON-PROFIT ORG.
U. S. POSTAGE
PAID
Lafayette, Indiana
PERMIT NO. 54

ST. ANDREW CONNECTIONS

St. Andrew UMC

Phone: 497-7755

Traditional Worship: Sunday 8:45 a.m.

Contemporary Worship: Sunday 11:00 a.m.

Sunday School: 10:00 a.m.

Childcare provided at all times

You can continue to access our web page at <http://andrew-umc.org>



Your St. Andrew Staff

Pastor:	Tim Burchill
CrossRoads Pastor:	Pat Sleeth
CrossRoads Dir. of Programs:	Dana Kirkwood
Administrative Secretary:	Donna Biehl
Financial/Office Asst:	Tricia Sembroski
Dir. of Children's Ministry:	Melissa Martin
Dir. of Music Ministry:	Dave Evans
Organist/Pianist:	LuAnn Boggess
Asst. Organist/Pianist:	Lisa Tally
Chancel Choir Director:	Ben Waltz
Dir. Of InTouch Ministry:	Monica Arrowsmith
Coordinator InTouch Ministry:	Laurie Klenosky
Joyful Sound Director:	Jeni Leaird
Caretaker:	Linda Hamilton
Nursery Coordinator:	Kathy Rogers

E-Mail Addresses

tim@andrew-umc.org
pat@andrew-umc.org —on sabbatical
dana@andrew-umc.org
donna@andrew-umc.org
tricia@andrew-umc.org
melissa@andrew-umc.org
dave@andrew-umc.org
luann@andrew-umc.org
lisa@andrew-umc.org
ben@andrew-umc.org
monica@andrew-umc.org
laurie@andrew-umc.org
jeni@andrew-umc.org
linda@andrew-umc.org
kathy@andrew-umc.org