

The CrossRoads Connection



A Youth and Young Adult Ministry of
St. Andrew United Methodist Church

Making a List

In my family, I'm the planner. It doesn't matter if it is coordinating school schedules or major family undertakings like a vacation. I like to have it planned. In fact, I think half the enjoyment I get from vacations is planning it. I review as many possible outcomes that I can envision. I consider how it coordinates with the other events that I'm usually already planning.



Dana Kirkwood is the Program Director for the CrossRoads community.

My son, Garrett, would tell you that I am not a planner; I am a dweller! He often suggests "Just let it go, Mom!" I would argue that I'm just preparing! As you will quickly learn, I find comfort in being ready for any situation at hand. So, it should come as no surprise that I started "dwelling" over my new tasks as your CrossRoads Director

of Programs. In typical "Dana fashion," I started making a list.

I've been volunteering with CrossRoads for a long time now. One would assume that I know the programming. Well, I do for the junior high students and volunteers. However, there

is so much more to CrossRoads than just the sixth, seventh, and eighth graders! We have an awesome senior high youth group and Sunday school. There is the young adults Sunday school group. We have tutoring on Tuesdays and puppets on Wednesdays. There is a catering group. There is an advisory board. There is a long list of prayer partners! We have a newsletter editor, for which, I for one am very thankful to have! We have webmasters, a

photographer, a special events group, and people that work on fundraising and missions. Plus, there are all those things that I haven't mentioned here. That is a LOT of things happening, and we are growing!

chipping in

So, you can see why after I moved into this position, I felt the need for a list! I had my list spread out across my desk when my mother called. She was checking in to see how things were going with all the changes in our house. So, I explained how I was making my list to get control of what I needed to know about my new position. As I was telling her about the programs, I mentioned that I was pretty overwhelmed by the idea that there was so much to learn. My mother,

(Continued on page 2)

Our VISION: The CrossRoads Youth Ministry of St. Andrew United Methodist Church embraces and supports the youth and young adults of our community and their families, seeks to inspire and guide their spiritual growth as Disciples of Jesus Christ, and then, empowers/challenges them to serve each other, the church and the whole world.

Chipping In....

(Continued from page 1)

with all the love a mother gives her grown adult worry-wart child, said, "Oh Dana, give your worries away in prayer." And she moved on to the next topic.

This has been the same advice she has given me for the past 42 years. It didn't matter the subject, my mother's first words of wisdom are always "prayer." Now, I know she's right. See, it didn't matter if it was boy troubles, worrying about grades at school, stress at work, or even my kids.... She'd say "Dana, give away your worries in prayer." I'll tell you growing up, that was not the advice I wanted to hear. Yet, honestly, it is always successful.

According to Matthew 7:7-8, we just need to "Ask and it will be given to you; seek and you will find; knock and the door will be opened to you. For everyone who asks, receives; he who seeks, finds; and to him who knocks, the door will be opened." Isn't

that cool? It is comforting to know that while I sit in the quiet of my house late in the evening



asking; God is listening, and He will give me the ability to conquer my list.

After talking to my mother and taking her advice, I sat down with my list and prayed over my concerns. My worries seem less daunting and more exciting now. I realize that I have a lot to learn about the individual programs. Yet, I am looking forward to spending some time in each group. I can't wait to get started talking to the leaders of these amazing programs on how their ministries work. I am looking forward to meeting new people in our congregation and helping them find places where they can fit within CrossRoads. And, I can't wait to hear from you!

I was ready to get started, and I pulled out my list. There on the top of the list was "Ask for Prayers." It appeared that I already knew what I needed long before I spoke to my mom! So, if you would be so kind to remember our CrossRoads Programs in your quiet time with God, I would be forever grateful. As I see it, for CrossRoads to continue to be successful, as a

**Remember,
you can always
access the CR
calendar on the
Web at
thecrossroads-
umc.org**



congregation, we need to regularly lift up the programs, the volunteers, the youth and young adults of our church in prayer. And most certainly, I would covet your prayers as well. This is a new journey for St. Andrew and for me... but I'm confident that with God's blessings, I plan to be "giving my worries away in prayer" for a long time.

Dana

APRIL Senior High Events

A calendar of future events to clip and place on your refrigerator

March 28

10a Sunday School

6p Youth Group

How are Methodists Different—
Pastor Pat discusses different
religions—all are welcome

April 4

9:30a Sunday School

Easter—No Youth Group

April 11

10a Sunday School

Fun Activity After Church

April 18

10a Sunday School

6p Youth Group

April 25

10a Sunday School

6p Youth Group

May 2

10a Sunday School

6p Youth Group

SEE YOU AT THE CROSSROADS

Senior Spotlight!

We are honoring today two seniors who have decided where they will attend college next year. These two people are involved in St Andrew and have been attending here for a long time. *More spotlights to follow in future newsletters !*

Samantha Akridge:

Samantha is a senior at West Lafayette High School where she has been involved in many activities during her four years there. Samantha has been a member of the Varsity Soccer team that won regionals. Samantha is also currently a member of the Varsity Track team, and this winter was one of the team managers for the Boys Varsity Basketball team. Even with so much of her free time tied up in sports, Samantha has been an active member of the West Side Service Organization, which is an organization whose goal is to provide helpful service to school and community. Samantha has been active at St. Andrew as well. She has spent her life here and was a long time participant in Vacation Bible School. The past few years she has volunteered as a camp counselor. She still attends Sunday School and helps her mother when she needs it. We are proud and honored that Samantha is a member of the Senior High community and wish her nothing but the best at Indiana University next year!!

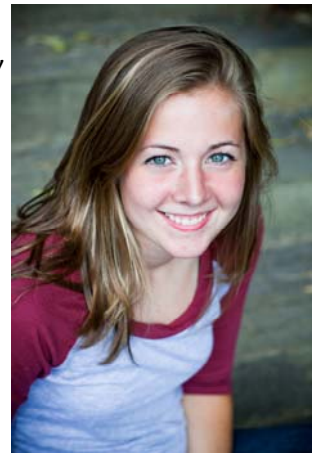

Taylor Honsowetz:

Taylor is a senior at McCutcheon High School where he has been a member of the school paper and many computer clubs. Taylor has really made his mark not at high school but here at St. Andrew and at Purdue University. At Purdue, Taylor has had a job for the last two years as a web programmer. Taylor has received high recognition for his computer programming of kiosks that are all over Purdue's campus. If you have ever been on campus and used a kiosk, then you owe Taylor a big thank-you. At St. Andrew there is nothing technological in our new church that Taylor hasn't had a hand in. He is in charge of the A-V system and in charge of all church computers. But the spot Taylor has really made his mark is in his dedication to others. Taylor is a huge supporter of mission trips and will be going on his 5th straight one this summer. He has been active in youth group, Sunday school and Vacation Bible School as well. We are proud and honored that Taylor is a member of the Senior High community and wish him nothing but the best at Purdue next year!!





CLASSES FOR YOUNG ADULTS

Please Join Us!

Young Adult Sunday School—The Young Adult class is using the Faithlink study source for their discussions each week. It focuses on current issues and how they affect our Christian lives. The Young Adult class meets in The Intersection

Grandma Can't Read!

On a recent visit, my mother was handed a furiously scribbled page of crooked lines by granddaughter Aubrey.

"Here, Grandma, look what I wrote," Aubrey said proudly.

Grandma peered at the unintelligible lines. "Very nice, Aubrey. What does it say?"

Aubrey shrugged, took the paper, and went to find her mother. "Mommy," she whispered anxiously, "Grandma can't read!"

—Robert Hostetler, Somerville, Ohio. Christian Reader, "Kids of the Kingdom."

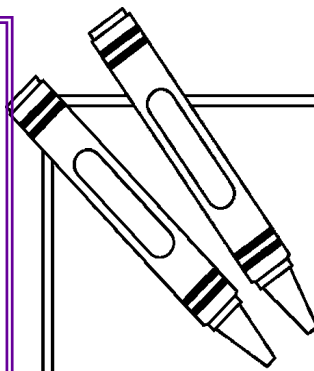

Just for KIDS

God's Promise

The Lord made a promise to Noah in Genesis 8:22. It was a covenant. Fit the words from the list into the crossword puzzle. Then use the numbers to match the words to the blank lines at the bottom.

as
and
the
day
cold
long
heat
heat
will
earth
night
never
cease
winter
summer
harvest
endures
seedtime

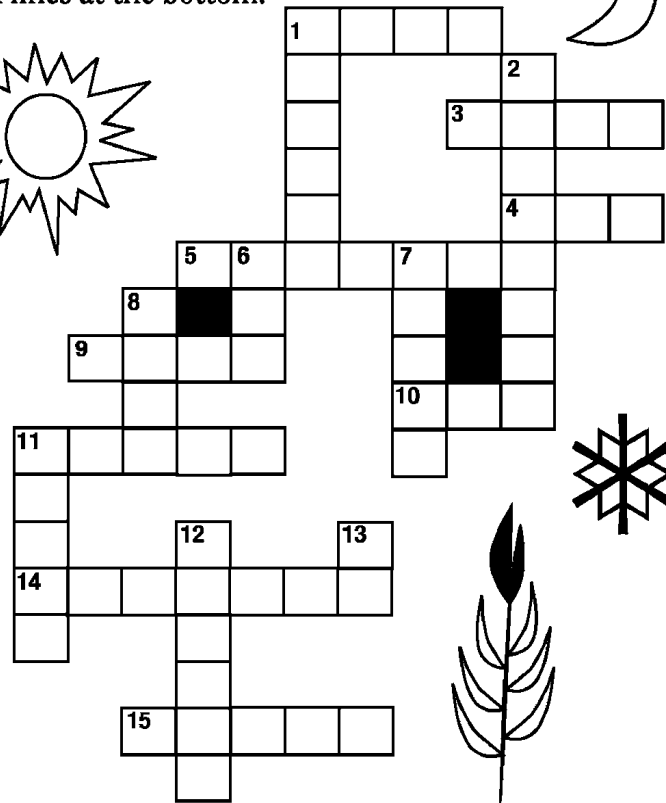
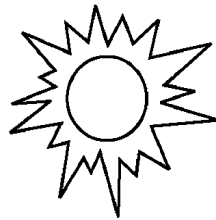

“
 _____ 13 _____ 8 _____ 13 _____ 10 _____ 7 _____ 14 ”
 _____ 2 _____ 6 _____ 5 ” _____ 9 _____ 6
 _____ 3 ” _____ 12 _____ 6 _____ 1 Down ” _____ 4
 _____ 6 _____ 11 Across _____ 1 Across _____ 11 Down _____ 15 ”

Answer:
 “As long as the earth endures, seedtime and harvest, cold and heat, summer and winter, day and night will never cease.”